

DN 150 CF

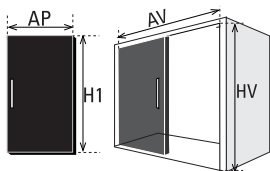

Riel DN150 AL
Trilho DN150 AL
DN150 Carrier Track



H1 = HV - 74 mm
AP = AV/2 + 60mm

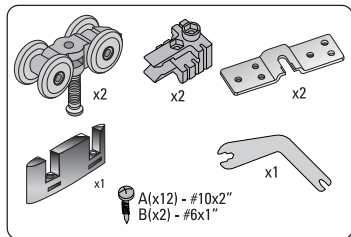

Todas las medidas expresadas en milímetros

Todas as medidas estão em milímetros.

All measurements in millimeters.

mm	Decimal inches	Aprox Fraction	mm	Decimal inches	Aprox Fraction
1	0.0394	3/64	6	0.2362	15/64
2	0.0787	5/64	7	0.2756	9/32
3	0.1181	1/8	8	0.3150	5/16
4	0.1575	5/32	9	0.3543	23/64
5	0.1969	13/64	10	0.3937	25/64

1

1.1

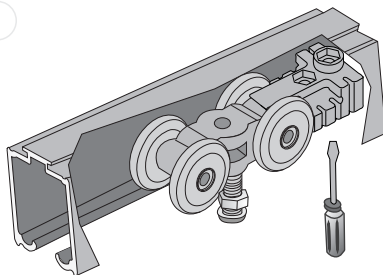

1.2

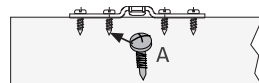
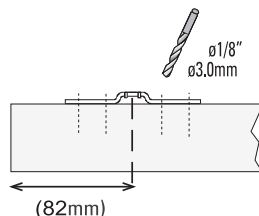

1.3

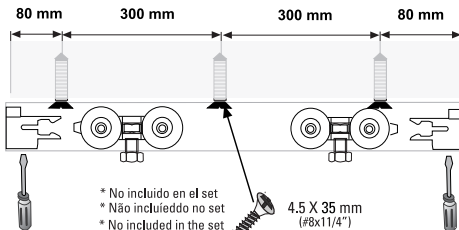

* No incluido en el set
* Não incluido no set
* No included in the set

4.5 X 35 mm
(#8x1/4")

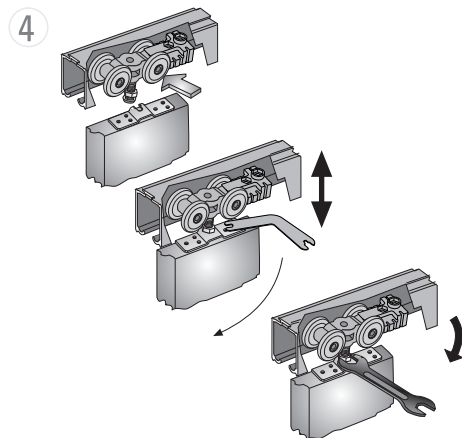
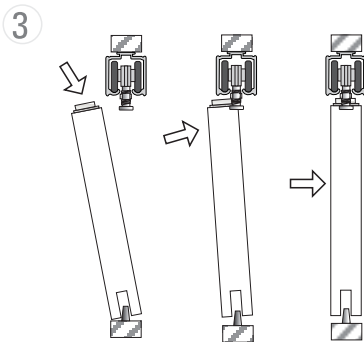
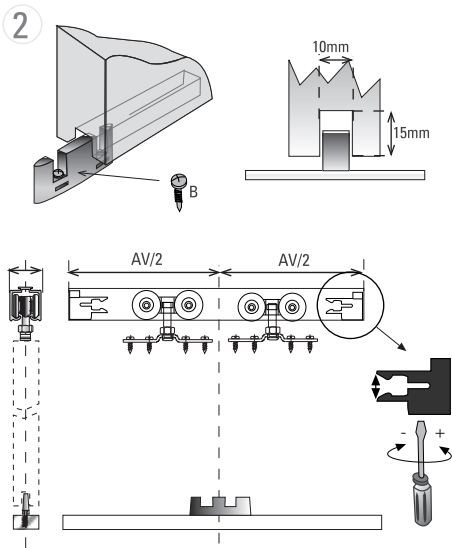

* ACCESORIOS / ACCESSORIES

Conector Muro Ancho
Conector Lateral Largo
Wide Wall Mounting Bracket
E= $\leq 50\text{ mm}$

Cenefa DN150
Sanefa DN150
Fascia DN 150
(E= $\leq 50\text{mm}$)



Sugerencia / Suggestion / Sugestão

